

Installation Instructions, Pressure Regulator – 20517 Series

Manual Model: 20517, L20517
Air motor Operated: F20517, LF20517
Hydraulic Motor Operated: G20517, LG20517



1. GENERAL ----- 02
2. INTENDED USE ----- 02
3. SAFETY INFORMATION ----- 03
4. TECHNICAL DATA ----- 04
5. INSTALLATION ----- 07
6. OPERATION ----- 07
7. TROUBLESHOOTING /MAINTENANCE & REPAIR INSTRUCTIONS -----09
8. TRANSPORT / STORAGE ----- 11
9. DISPOSAL / RETURNS ----- 11
10. NAMEPLATE ----- 12
11. WARRANTY ----- 12
12. MANUFACTURE AND INQUIRIES ----- 12

Barksdale
CONTROL PRODUCTS

Barksdale Inc.
3211 Fruitland, Ave
Los Angeles, CA 90058

Phone: 800 835-1060
Fax: 323 589-3463
e-mail: sales@barksdale.com



Bulletin No. 272372-B
Date: 07-05-2013
Document & specifications are subject to
change without notice.

1.0 GENERAL

To ensure proper and safe operation of a Barksdale Regulator, the entire manual must be read and understood clearly. Please pay special attention to all safety information.

 This sign is used in this instruction in case of hazards which might result in injuries and damages.

2.0 INTENDED USE

Barksdale's pressure regulators are sensitive, pressure-control devices used to maintain a pre-determined pressure in a hydraulic circuit. The regulated output pressure is controlled by adjusting the spring force by air or hydraulic motor or manually to balance the hydraulic loading. Design features ensure excellent accuracy, repeatability and high flow coefficients. This regulator works on Shear-Seal® technology which uses fluid pressure to maintain a leak-free metal to metal seal.

3.0 SAFETY INFORMATION

The recommendations below are general and it is the responsibility of the user to assure that installation and maintenance are in accordance with local requirements, API and ASME practices. This valve should be installed by a trained service person. A media filter should be in the system to protect the regulator. It should not be installed for safety purpose. To maximize life it is suggested to follow ISO fluid cleanliness code ISO4406:1999 or thereafter. Neither Barksdale nor its agents assume any liability for regulator improperly used in the application or improperly installed and maintained.

3.1 Marking of safety instructions in the operating manual

The safety instructions are intended to protect the user from dangerous situations and/or material damage. In the operating instructions the seriousness of the potential risk is designated by the following signal words:

 **Warning:** Safety Instructions whose non-observance may be hazardous to persons, and/or cause damage to property.

 **Caution:** Safety Instructions whose non-observance may lead to product damage, or loss of function. Product Marking: Nameplate and label marking on the equipment itself contains the primary functional limits information. This information must be absolutely followed and kept in legible condition.

3.2 Qualifications and training of personnel

Operating, maintenance, inspection and installation personnel must be qualified to carry out their respective duties. Areas of responsibility, competence, and proper levels of supervision should be clearly defined by the user. If personnel are not sufficiently qualified, additional training and instruction should be carried out, to ensure that operating instructions are fully understood by the responsible personnel.

3.3 Non-compliance with safety instructions

Non-compliance with these safety instructions can jeopardize the safety of personnel, the environment, the regulator and/or the system. Non-compliance with these safety instructions will lead to forfeiture of any rights to claims for damages.

3.4 Safety Awareness

It is essential to comply with the safety instructions contained in this manual, along with the relevant national, state and local health and safety regulations, and the operator's own internal operating and safety instructions.

3.5 Safety instructions for the operator/user

Isolate the regulator from all system pressure before performing any service procedures. Leakage of any dangerous liquids (toxic or hot) at any exterior mechanical joint seal must be drained off without any danger to persons or the environment. All Federal, State and Local Rules regarding chemical disposal and handling must be followed.

3.6 Safety instructions for maintenance, inspection and installation work

The user must ensure that all maintenance, inspection and installation work is carried out by authorized personnel, who are familiar with the manual. As a rule all work on the unit should only be carried out after the regulator has cooled down and pressure has been released. Proper tag out or lockout is strongly recommended. Immediately after completion of work, all safety and protective devices in system should be refitted and fully functional. Please observe all relevant system start-up safety rules.

3.7 Unapproved modifications and use of non-genuine spare parts

Modifications or changes to the unit are only permitted upon approval of Barksdale. Only genuine spare parts and original accessories will ensure the safety of the unit. The use of other than original parts voids the warranty and will lead to forfeiture of the declaration of conformity and will invalidate any liability for damages caused thereby.

3.8 Unapproved usage

The operating reliability and safety of the regulator is only valid if used in accordance with its specified technical limits as described in the Installation and operating instructions. Any other use is not in conformity with the regulations, and Barksdale will not be liable for any resulting damages.

The installation and operating manual does not invalidate general regulations and standards not referred to general technical rules should be observed.

4.0 TECHNICAL DATA

4.1 Technical Specification

Specifications has been mentioned on provided catlog or sales drawing with the product.

Table 1. Product Specifications

| Specifications: | Regular Hydraulic Regulator 20517 | Land Regulator L20517 | |
|---|--|-----------------------------------|-------------------------------|
| Supply /Inlet Pressure | 3,000 psi (207bar) | 3,000 psi (207bar) | 5,000 psi (345 bar) |
| Regulated Pressure Range: | | | |
| Manual | | | |
| High Sensitivity | 200 - 1600 psi (14 -110 bar) | 300 - 1600 PSI (21 -110 bar) | 500 - 1600 PSI (34 -110 bar) |
| Full Range | 350 - 2800 psi (24-193 bar) | 300 - 2800 PSI (21 - 193 bar) | 500 - 3000 PSI (34 - 207 bar) |
| "F" Prefix Pneumatic failsafe motor: | | | |
| High Sensitivity | 200 - 1600 psi (14 -110 bar) | 300 - 1600 PSI (21 -110 bar) | 500 - 1600 PSI (34 -110 bar) |
| Full Range | 350 - 2800 psi (24-193 bar) | 300 - 2800 PSI (21 - 193 bar) | 500 - 3000 PSI (34 - 207 bar) |
| "G" Prefix Hydraulic failsafe motor: | | | |
| High Sensitivity | 200 - 1600 psi (14 -110 bar) | 300 - 1600 PSI (21 -110 bar) | 500 - 1600 PSI (34 -110 bar) |
| Full Range | 350 - 2800 psi (24-193 bar) | 300 - 2800 PSI (21 - 193 bar) | 500 - 3000 PSI (34 - 207 bar) |
| Fluid Temperature Range: | -40° to +250°F (-40° to +121°C) | -30° to +185°F (-34° to +85°C) | |
| Proof Pressure: | 4,500 PSI (310 bar) | 4,500 PSI (310 bar) | 7,500 PSI (517 bar) |
| Flow: | | | |
| Flow Rate: | 120 GPM (@ 50 ft/s) | 120 GPM (@ 50 ft/s) | |
| Cv Inlet: | 17.5 | 17.5 | |
| Cv Vent: | 1.6 | 1.6 (18 GPM @ 50 ft/s) | |
| Porting: | | | |
| Inlet 1: | 1" NPT Standard, SAE Optional | 1" NPT Standard, SAE Optional | |
| Inlet 2: | 1" NPT Standard, SAE Optional | 1" NPT Standard, SAE Optional | |
| Outlet (regulated): | 1-1/2" NPT Standard, SAE Optional | 1-1/2" NPT Standard, SAE Optional | |
| Vent: | 1" NPT Standard, SAE Optional | 1" NPT Standard, SAE Optional | |
| Materials of Construction: | | | |
| Body: | Phosphate coated alloy steel (std.) Option: Stainless steel | Phosphate coated Ductile Iron | |
| Flanges: | Phosphate coated alloy steel (std.) Option: Stainless steel | Phosphate coated Carbon Steel | |
| Spring Tower: | | | |
| Manual | Phosphate coated alloy steel (std.) /SS | Phosphate coated Carbon Steel | |
| Pneumatic Motor model | Painted alloy steel (std.) /SS | Phosphate coated Carbon Steel | |
| Hydraulic Motor model | Painted alloy steel (std.) /SS | Phosphate coated Carbon Steel | |
| Socket Head Screws: | Stainless Steel (std.) | Zinc plated alloy steel | |
| Standard O'ring Material: | Buna N | Buna N | |
| Wetted Parts: | Stainless steel & Bronze | 400 series Stainless Steel | |
| Pneumatic Pilot Motor ("F" Prefix) | | | |
| Pilot Motor Working Pressure: | 80 - 120 PSI (5.5 - 8.3 bar) | 80 - 120 PSI (5.5 - 8.3 bar) | |
| Porting: | 1/4" NPT | 1/4" NPT | |
| Operating Temperature Range: | 32° to +250°F (0° to +120°C) | -30° to +185°F (-34° to +85°C) | |
| Hydraulic Pilot Motor ("G" prefix): | | | |
| Pilot Motor Working Pressure: | 400 - 1600 PSI (27.6 - 110.3 bar) | 400 - 1600 PSI (27.6 - 110.3 bar) | |
| Porting: | SAE for 3/8" Tube (Size -6) | SAE for 3/8" Tube (Size -6) | |
| Operating Temperature Range: | -40° to +250°F (-40° to +121°C) | -30° to +185°F (-34° to +85°C) | |
| Approximate Shipping Weight: | | | |
| Manual: | 67 lbs. (30.4 kg) | 70 lbs. (31.8 kg) | |
| Pneumatic & Hydraulic Motor | 90 lbs. (40.8 kg) | 90 lbs. (40.8 kg) Both | |

4.2 Product Configurator

Figure 1. Product Configurator for Regulator 20517

| | | | | |
|--------------------------|---------------------------|---|--------------------------------|-------------------------------|
| EXAMPLE: | | 20517S3WQ2 | | |
| Adjustment Method | | Option | | |
| Blank | Manual | Blank | NPT porting | |
| F | Pneumatic failsafe motor | - MS | SAE porting | |
| G | Hydraulic failsafe motor | - SS | Stainless steel Flanges & trim | |
| Series | | Regulated Pressure Range (Manual & Failsafe - F & G) | | |
| 20517S3WQ2 | 1 1/2" Pressure Regulator | Blank | High sensitivity | 200 - 1600 psi (14 - 110 bar) |
| | | -1 | Full range | 350 - 2800 psi (24 - 193 bar) |

Figure 2. Product Configurator for Regulator Land 20517

| | | | | |
|--------------------------|---------------------------------|---|-------------------|-------------------------------|
| EXAMPLE: | L | | 20517S6HQ2 | |
| Application | | Option | | |
| L | Land based Hydraulic Regulators | Blank | NPT porting | |
| | | - MS | SAE porting | |
| Adjustment Method | | Regulated Pressure Range (Manual & Failsafe - F & G) | | |
| Blank | Manual | Blank | High sensitivity | 300 - 1600 psi (21 - 110 bar) |
| F | Pneumatic failsafe motor | | | 500 - 1600 psi (34 - 110 bar) |
| G | Hydraulic failsafe motor | -1 | Full range | 300 - 2800 psi (21 - 193 bar) |
| | | | | 500 - 3000 PSI (34 - 207 bar) |
| Series | | | | |
| 20517S6HQ2 | 1 1/2" Pressure Regulator | | | |

4.3 Overall Dimensions

Figure 3. Dimensions for regular 20517 regulator

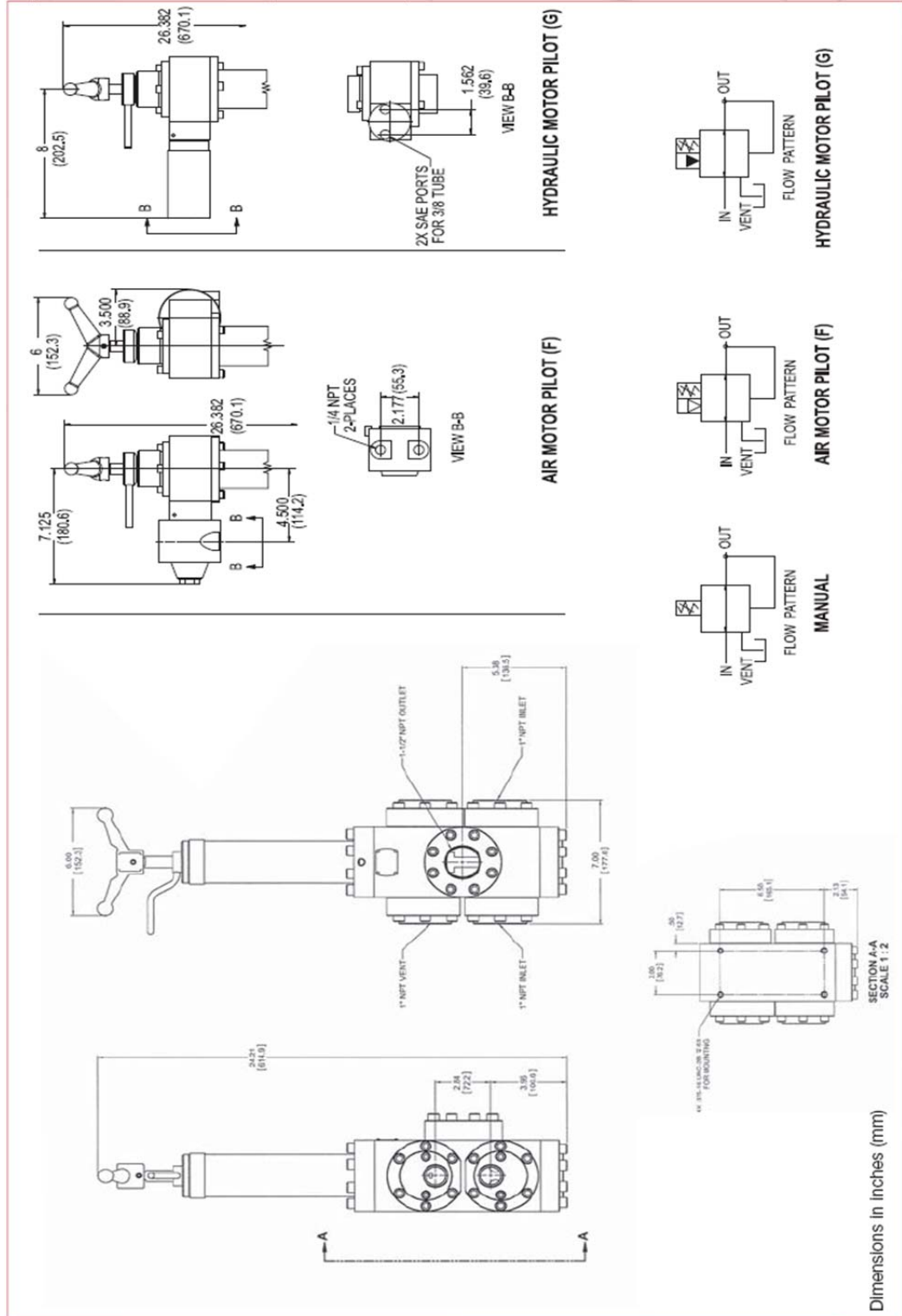

5.0 INSTALLATION

Make sure of ports are clean from debris that may have accumulated during storage or transportation. Confirm system operating condition before installation and should be as per regulator specifications.

⚠ Caution: *Pressure regulator should be installed in an assembly where the design pressure of the system downstream of the device is lower than the pressure which can occur upstream of the device and the system downstream should be protected by a safety accessory.*

5.1 Install regulator horizontally or vertically using mounting holes (3/8-16 UNC-2B), 4 places.

5.2 Connect pipes – (2) 1” NPT Inlet, 1-1/2” NPT Outlet, 1” NPT Vent to assemble regulator in your system. SAE port option is available as per customer requirement.

5.3 If required, connect supply line to Air pilot or Hydraulic pilot motors for adjusting the pressure set point.

6.0 OPERATION

The Regulator 20517/Land 20517 is a 1-1/2” valve having options for manual operation, Air motor operation or hydraulic motor operated. The regulator comes set at the mid-point of the pressure range. Follow these instructions to adjust the set point.

⚠ Warning: **Be sure that system pressure has been vented prior to operation.**

6.1 For manual Regulator, loosen the locking handle, rotate the adjusting handle down to desired pressure and set the locking handle tight. Note: If locking handle is not fully engaged adjustment handle will spin freely during motor operation.

6.1.1 To increase pressure, rotate handle clockwise, to decrease pressure, rotate the handle counter-clockwise. Always tighten the locking handle after setting the regulator.

6.2 For Failsafe Regulator, the locking handle must be tight for the motors to engage.

6.2.1 To adjust set point, apply pressure to pilot port "A" for an increase in set point and to port "B" for a decrease in set point. Required range as in Table 2.

Table 2.

| Set Point operating Condition | Port Size | Pressure Range | Operating Temperature |
|--------------------------------|-------------------|-----------------------------------|----------------------------------|
| Air motor Pilot Pressure | 1/4" NPT | 80 - 120 PSI (5.5 - 8.3 bar) | 32° to +250°F (0° to +120°C) |
| For Land Version | 1/4" NPT | 80 - 120 PSI (5.5 - 8.3 bar) | -30° to +185°F (-34° to +85°C) |
| Hydraulic motor Pilot Pressure | SAE for 3/8" Tube | 400 - 1600 PSI (27.6 - 110.3 bar) | - 40° to +250°F (-40° to +121°C) |
| For Land Version | SAE for 3/8" Tube | 400 - 1600 PSI (27.6 - 110.3 bar) | -30° to +185°F (-34° to +85°C) |

NOTE: Regulator is designed to work with oil-based hydraulic fluid as well as with lubricated water.

6.3 Regulators work according to below flow patterns shown in Figure 5.

Figure 5.

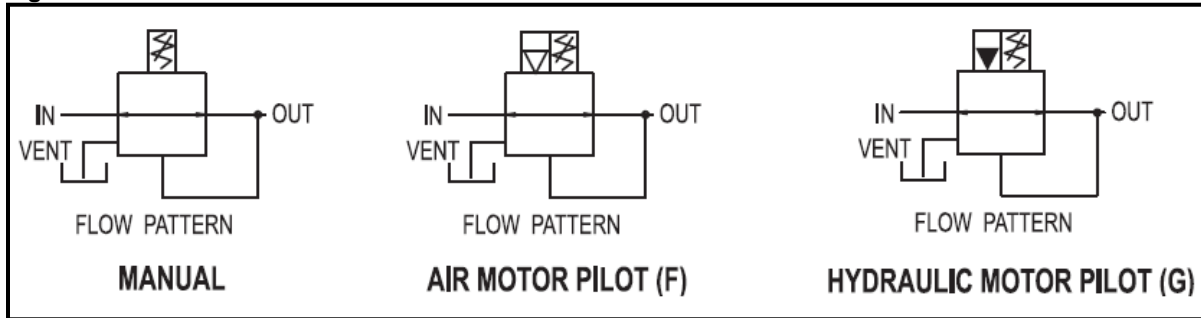

7.0 TROUBLE-SHOOTING

! Caution Chart (Table 3) is used as a quick trouble shooting tool and mainly for reference only. It does not mean to list all possible causes and solutions to the problems as seen by the user on Regulator. Contact factory or authorize dealers for technical support and issues.

Table 3.

| PROBLEM | POSSIBLE CAUSE | SOLUTION / RECOMMENDATION |
|-------------------|---|---|
| No Actuation | No pilot pressure | Provide pressure to pilot line |
| | Pilot line pressure blocked | Only one pilot port may be pressurized at a time. |
| | Locking handle not tight | Tighten handle with rubber mallet. |
| | Pilot line leaking | Tighten or replace pilot line. |
| External leakage | Loose connections | Tighten connections. |
| Internal leakage | Wear/Tear of pressure seals and O rings | Replace with new Seals and O-Rings. |
| High Leakage Flow | Slide Stuck, Pressure seals stuck or lifted | Contact factory. |

7.1 MAINTENANCE INSTRUCTIONS

CAUTIONS

All repair of Barksdale ShearSeal® Regulators should be performed in a clean area free of excess dirt and debris. The ShearSeal® components are manufactured to precise tolerances and can be damaged if proper care is not taken.

WARNING

Isolate the regulator from all system pressure before performing any disassembly procedures.

! Exploded view provided by Barksdale and/or distributor for reference only. It is strongly recommended that all repairs and kit installations are completed by appropriately trained personnel. The customer will assume all risk associated with the use of unauthorized parts or personnel.

SERIES 20597

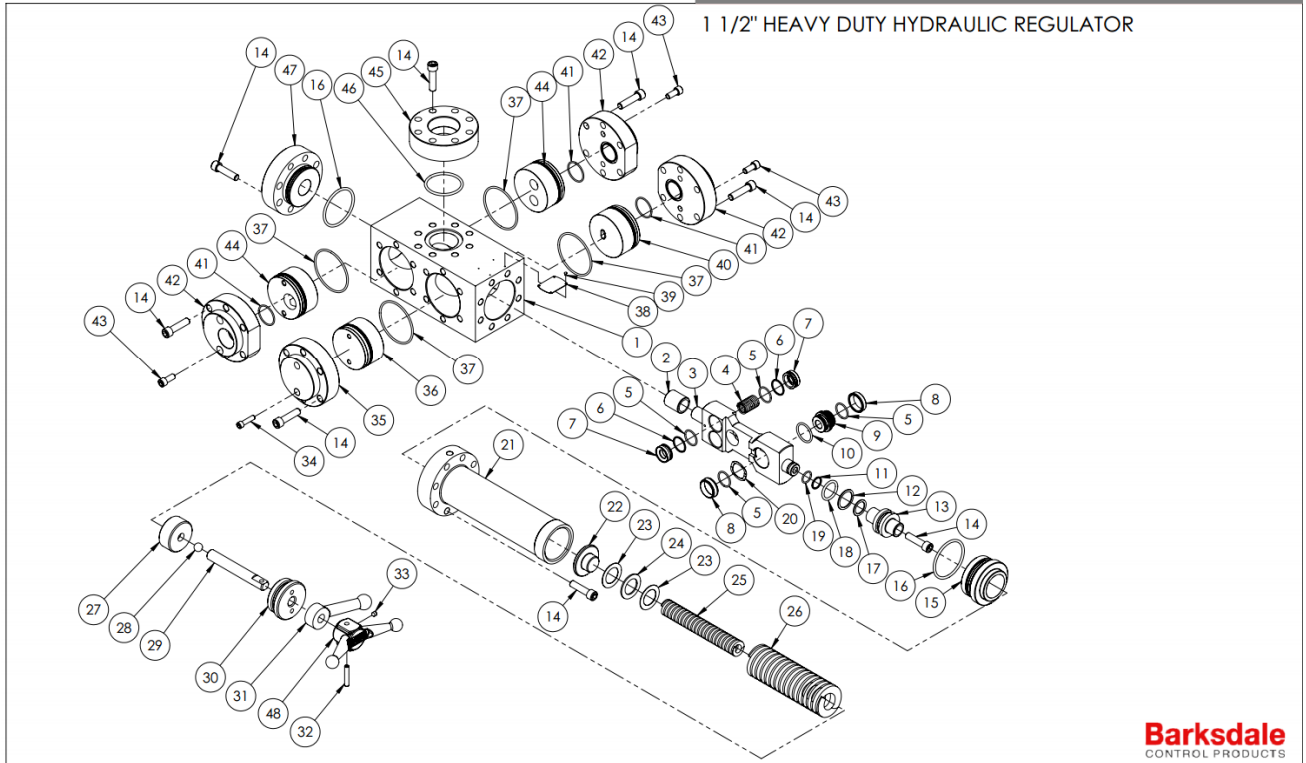

Disassembly

1. Disconnect all fittings from the regulator and pilot motor
2. Turn locking device(31) counterclockwise first to unlock. Turn handle(48) counterclockwise to remove load from compression springs
3. Remove spring housing bolts(14)
4. Lift the spring housing assembly(21) together with spring(25, 26) and SPRING gland(22)
5. Remove flanges
 - a. Remove bolts(14) from inlets, vent(42) and blind(35) flanges, pull the flanges out
 - b. Remove bolts(14) from bottom(47) flange, pull out flange
 - c. Note: If using major repair kit, remove bolts (43) from inlet and vent flange (42) and blank flange (35). Remove inlet plate (44) vent plate (40) and blocking plate (36).
6. Remove piston gland(15) and push out the slide assembly(3, 13) towards the top, Remove piston(13) and slide(3)
7. Take out pressure seals(8, 7) from slide(3)
8. Uninstall all soft goods (o-rings and back-up rings)

Cleaning and Inspection

1. Thoroughly clean and inspect the slide(3) and piston assembly(3, 13). Look for signs of wear, replace if necessary
2. Thoroughly clean and inspect the wear plates(44, 40, 36) on the internal side of the inlet(42), vent(42) and plain(35) flanges. Look for signs of wear or scratching, replace if necessary.
3. Inspect all pressure seals(8, 7) for wear, if signs of damage, replace.
4. Check all o-rings, back-up rings and washers, replace if necessary.

Re-assembly

1. Lightly lube all soft goods from Repair Kit with petroleum based lube (mobile lube)
2. Re-install all o-rings (wherever back-up rings are used, refer to exploded view drawing to assure proper orientation of back-up rings in relation to o-rings)
3. If using major repair kit, ensure o-rings (41) are installed prior to aligning all plates and flanges and secure flanges with bolts (37), torque to 140-180 in-lbs.
4. Re-install pressure seals(8, 7), spring (4) and piston vent(9) back into the slide(3) (make sure back-up o-rings are not extruding)
5. Insert bottom flange(47) first.

6. Insert bottom flange bolts(14) by hand (do not tighten yet)
 7. Insert slide(3) and piston assembly(3,13) from top face. Guide the slide (3) into the bottom flange bushing (2)
 8. Insert the piston gland(15)
 9. Insure up-down movement of slide by hand to make sure it travels freely
 10. Tighten the bolts(14) at the bottom flange(47)
 11. Install ALL flanges: Starting with the outlet(45) than the inlet(42) and vent(42). *Verify orientation* Then Proceed to tilting the regulator so that the inlet(42) flange is laid down to prevent the PRESSURE SEALS(7, 8) from falling when installing the 2nd inlet(42) and blind(35) flange.
 12. Tighten bolts (14) on all flanges and spring housing to 192-240 in-lbs.
 13. Place spring housing assembly(21) into place and tighten the spring housing bolts (14)
 14. Turn handle(48) all the way in (preload compression spring 3-4 turns clockwise)
- Assembly is complete

8.0 TRANSPORT / STORAGE

Severe shock and vibration should be avoided during transport. Store it in a clean and dry environment. Regulator is ready for operation upon delivery. The protective port plugs should not be removed until immediately before plumbing the regulator. **To avoid damaging regulator or/and pilot motor, do not lift or carry by the handle.**

It is recommended to transport it with the lifting equipment suitable for the weight to be moved. Do not hook-up lifting equipment to accessory such as handle, or pressure bores. When using a suspension belt it must be placed around the regulator body, providing edge protection and ensuring weight distribution. Transport/storage temperature is recommended to be between -40° C (-40° F) to +93°C (200°F). Protect existing sealing surface on the connections from damage. Do not damage the corrosion protective layer.

9.0 DISPOSAL / RETURNS

Regulator that has come in contact with health – threatening media must be decontaminated prior to disposal or returned to Barksdale.

Follow proper Federal/ State and local regulations for appropriate disposal to protect the environment.

10.0 NAMEPLATE



Nameplate is permanently secured to one side of regulator body with the followings information: model part number, working pressure (WPR) and serial number (SN). The first 6 digit numbers of the serial number represent the date of manufacture (MM month/ DD date/ YY year).

11.0 WARRANTY

See Barksdale "STANDARD TERMS AND CONDITIONS" document for **STANDARD WARRANTY**.

12.0 MANUFACTURE AND INQUIRIES

Please contact Customer Care for product inquiry or any product related questions or issues.

Barksdale
CONTROL PRODUCTS

3211 Fruitland Avenue
Los Angeles, CA 90058
Phone: (800)-835-1060
Fax: (323)-589-3463
www.barksdale.com